

# LF10-L

Air compressor pressure switch

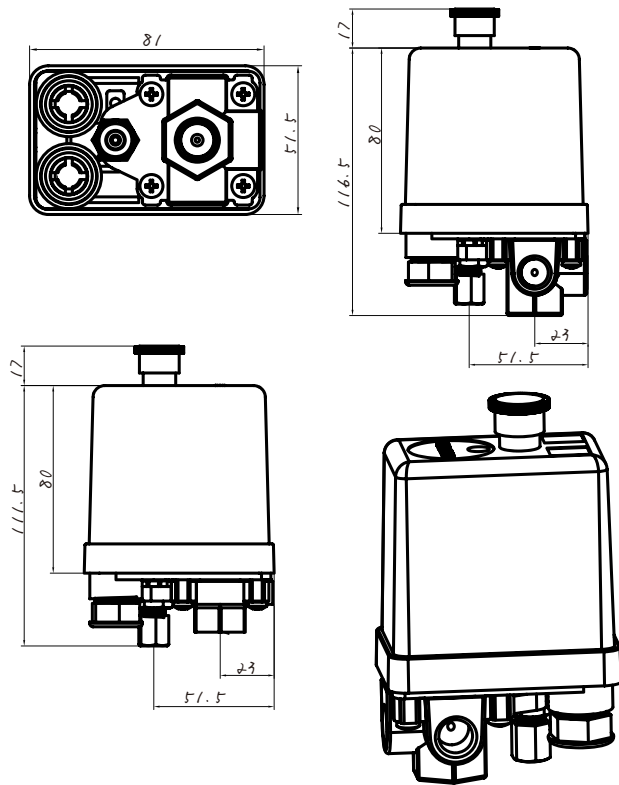

**LEFOO**



Dimension in:mm

The LF10-L pressure switch is a pressure-operated electric switch for use in regulating the tank pressure between two preset values on electrically driven air compressors. It is available with an unloader valve, which prevents compressors from starting under load, and an On-Off button for manual cut off the compressor. A four port manifold style is available.

## LF10-L Order Ref NO

LF10-L -4 H 1 1 1 2 -85psi-115psi

**A B C D E** Pressure setting:Cut in 85psi Cut off 115psi

Number	Connection Type	Connection Size	Unloader Valve Type	Unloader Valve Connection
0	/	/	/	Without
1	single port <b>B</b> female	<b>C</b> 1/4NPT	<b>D</b> Copper	Φ6.0mm
2	/	3/8NPT	Plastic	<b>E</b> Φ6.4mm
3	/	R1/4	/	Φ6.5mm
4	<b>A</b> four ports	R3/8	/	/
5	/	G1/4	/	/
6	/	G3/8	/	/

## Specification

Model	Media	Operating Pressure Range	Factory Setting	Differential	Electrical Rating	Contact Arrangement	Connection
LF10-L1H	Air	45-175psi	85-115psi	30-45psi	120VAC, 20A	NC	G1/4,G3/8 or 1/4,3/8NPT Female
LF10-L4H	Air	45-175psi	85-115psi	30-45psi	120VAC, 20A	NC	G1/4,G3/8 or 1/4, 3/8NPTFemale (Four ports)

Other pressure settings and differential are available on request.  
 Other connections are available on request.  
 Conversion:1kgf/cm<sup>2</sup>=14.2psi 1bar=14.5psi