

Electromechanical time switches

ELO

DIMENSIONS (mm)

CONNECTION DIAGRAM

Electromechanical time switches with trippers for daily or weekly programming and with charge reserve for domestic use.
The battery can be replaced with ease once depleted by opening the side cover of the instrument.

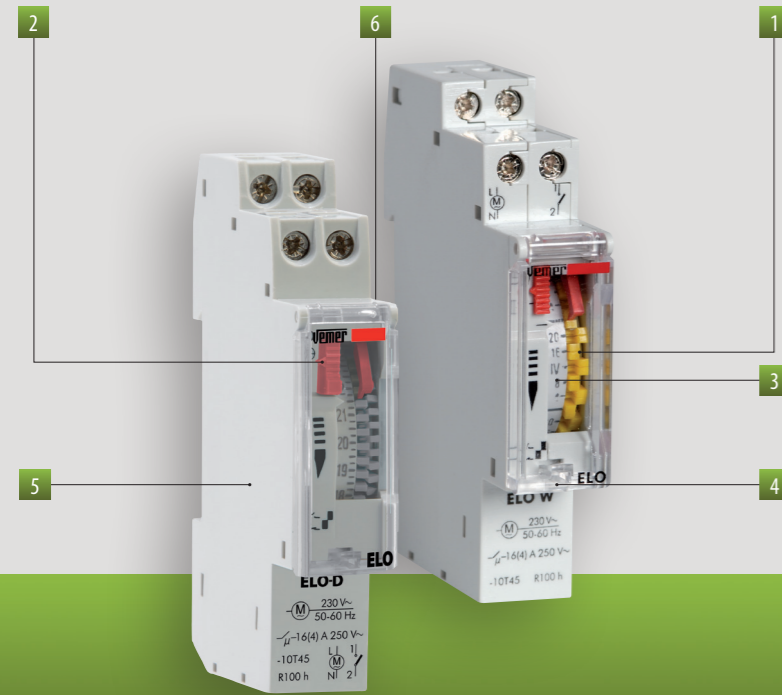

- 1 Trippers for the programming of the time activation
- 2 Switching for the choice of the operating mode
- 3 Dial for time and minutes setting
- 4 Sealable cover
- 5 Container: 1 DIN module
- 6 Cover for battery replacement

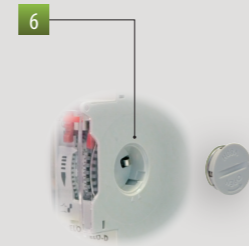

Front view

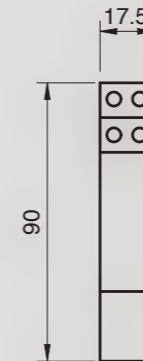

Side view

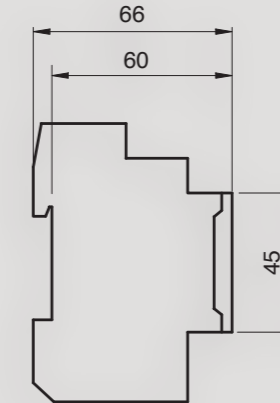

Diagram

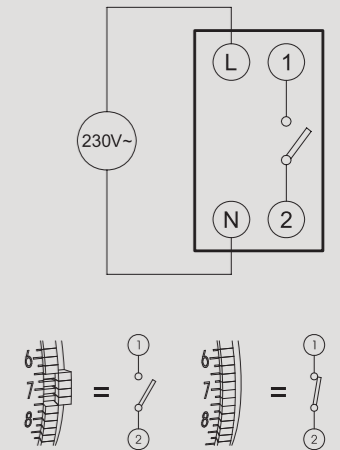

TIME MANAGEMENT

DAILY/WEEKLY TIME SWITCHES

- Power supply: 230 V AC (-15% ÷ +10%)
- Output relays capacity: 16(4) A / 250 Vac
- Operating modes:
 - 0 always off
 - ☉ automatic (following the programming set with the trippers)
 - I always on
- NiMH (V80H type) rechargeable and replaceable by the side cover of the instrument
- Charge reserve: 150 hours



ELO-D

- daily programming
- quadrant of 24 hours with 96 trippers
- every tripper covers 0.25 hours (15 minutes)



ELO-W

- weekly programming
- quadrant of 7 days with 84 trippers
- every tripper covers 2 hours (120 minutes)

TECHNICAL INFORMATION

GENERAL CHARACTERISTICS

Power supply	V AC	230 (-15% ÷ +10%)
Frequency	Hz	50 / 60
Absorption	W	0.5
Output relays capacity		16(4) A / 250 Vac
Operating precision		± 1 second/day at 22°C
Type of quadrant	- ELO-D	96 trippers
	- ELO-W	84 trippers
Minimum intervention time	- ELO-D	15 minutes
	- ELO-W	2 hours (120 minutes)
Intervention precision:	- ELO-D	±5 minutes
	- ELO-W	± 30 minutes
Charge reserve	- ELO-D	150 hours (NiMH battery rechargeable replaceable)

Operating temperature	-10 °C ÷ +50 °C
Protection class	II
Protection degree	IP20
Container	1 DIN module

CONNECTABLE LOADS

Incandescent		2500 W
Fluorescent (neon)		1200 VA
Low voltage halogen		2000 VA
Halogen (230 V~)		2500 W
Low consumption (CFL)		1000 VA
Low consumption (CFL)		900 VA
Led		100 VA

Code	Model	Description
VP877500	ELO-D	Daily electromechanical time switch with replaceable battery
VP878300	ELO-W	Weekly electromechanical time switch with replaceable battery

REFERENCE STANDARDS

Compliance with Community Directives: 2006/95/EC (Low Voltage) and 2004/108/EC (E.M.C.) is declared with reference to the following standard: • EN 60730-2-7