

Part number

CHV 24



Brief description:

hoods for two levers, size "104.27", top entry, Pg21, metal version, IP66

Product description

Version	metal version
Series	hoods for two levers
Product type	with 4 pegs
Variant	top entry
Family	CLASS enclosures
Size	size "104.27"

Technical data

Material	metal
IP degree of protection	IP66 (and IP69K DIN 40050 - 9)
Cable entry	Pg21

Further technical details

Weight	170,00 g
--------	----------

Approvals / Standards

Quality mark	 (type:4/4X/12),  , EAC
Conformity	CQC, CE

General ordering information

EAN13 code	8015747024648
Tariff number	85369095

Packaging Information

Packaging length	225,00 mm
Packaging height	155,00 mm
Packaging width	265,00 mm
Packaging weight	3,70 kg
Packaging volume	9,24 dm ³
Packaging description	Carton box
Packaging quantity	20 Pcs
Packaging EAN code	8015747024655
Sub-packaging weight	0,93 kg
Sub-packaging description	Plastic packaging
Sub-packaging quantity	5 Pcs
Sub-packaging EAN barcode	8015747024662

Part number

CHV 24



Catalogue drawings

**CHO [CAO] CHV (CAV) - MHO [MAO]
MHV (MAV)**

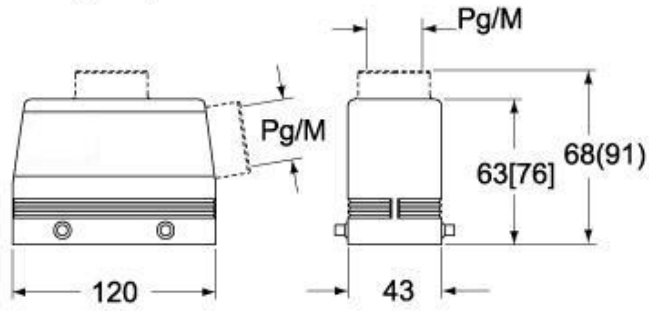

CHV G (CAV G) - MHV G (MAV G) - [MFV G]

